

# Original Operating Instructions Flame Scanner

**Type:** 2.0GT

**Document:** BA 2.0GT EN Rev.3



BFI Automation  
Dipl.-Ing. Kurt-Henry Mindermann GmbH  
Eggerscheidter Strasse 57  
D-40883 Ratingen Germany  
Telephone +49 (2102) 9682-0 · Facsimile +49 (2102) 9682-42  
<http://www.bfi-automation.de>

---



<b>1</b>	<b>General aspects</b>	<b>1-1</b>
1.1	Introduction	1-1
1.2	Warning notes	1-2
1.3	Copyright protection	1-3
1.4	Disposal information	1-3
1.5	Warranty	1-4
1.6	Obligation of the operating company	1-5
1.7	Liability disclaimer	1-6
1.8	Declaration of conformity	1-7
1.9	Address of the manufacturer	1-8
<b>2</b>	<b>Safety</b>	<b>2-1</b>
2.1	Intended use	2-1
2.2	Requirements on persons	2-2
2.3	Safety instructions	2-3
2.4	Safety devices	2-4
2.4.1	Fundamental aspects	2-4
2.4.2	Safety devices on the flame scanner	2-4
2.5	Safety instructions in case of maintenance and troubleshooting	2-5
2.5.1	Fundamental aspects	2-5
2.5.2	Electrical / electronic devices	2-6
2.5.3	Testing in keeping with the German Workplace Safety Ordinance (BetrSichV)	2-7
2.5.4	Safety test	2-7
<b>3</b>	<b>Technical data</b>	<b>3-1</b>
3.1	General characteristic features	3-1
3.2	Electrical system, optical system, mechanical system	3-1
3.3	Weight	3-2
3.4	Dimensions	3-2
3.5	Adjustment controls	3-3
3.5.1	Sensitivity potentiometer	3-3
3.5.2	Optical aperture	3-4
3.6	Device design - block diagram of the flame scanner	3-5
<b>4</b>	<b>Transport, installation and connection</b>	<b>4-1</b>
4.1	Scope of delivery	4-1
4.2	Packaging	4-2
4.3	Forwarding instructions	4-2
4.4	Weight - flame scanner	4-2
4.5	Space requirement	4-2
4.6	Installation	4-3
4.6.1	Company adjustment of the flame scanner	4-6
4.6.2	Adapting the flame scanner to the fuel	4-7
4.7	Connection	4-8
4.7.1	Electrical connection	4-8
4.7.2	Laying the special cable KW5	4-9
4.7.1	Handling of the KW5-Shieldings	4-10
4.8	Storage	4-10

---

<b>5</b>	<b>Description</b>	<b>5-1</b>
5.1	Functional description	5-1
<b>6</b>	<b>Operation of the flame scanner</b>	<b>6-1</b>
6.1	Test of the flame scanner	6-1
<b>7</b>	<b>Maintenance and servicing</b>	<b>7-1</b>
<b>8</b>	<b>Failures</b>	<b>8-1</b>
<b>9</b>	<b>Order data</b>	<b>9-1</b>
<b>10</b>	<b>Accessories</b>	<b>10-1</b>

# **1 General aspects**

## **1.1 Introduction**

These operating instructions are a helpful guide for ensuring the successful and safe operation of the flame scanner. They contain important information on how to operate the system safely, correctly and efficiently. Observing the operating instructions will help to prevent hazards, reduce costs of repair and downtimes and increase the reliability and life of the device.

All illustrations and drawings in these operating instructions are shown for illustration purposes and do not contain details for design.

The operating instructions always have to be accessible at the device. They have to be read and applied by each person who is required to work with/on the device.

This work may involve, for example:

- operation
- troubleshooting during operation
- servicing
- maintenance (upkeep, inspection, repair) and/or
- transport

This should be confirmed by the operating company in writing.

## 1.2 Warning notes

The following warning notes are used in these operating instructions:

### **⚠ DANGER**

*This warning level indicates an imminent hazardous situation.*

*If the hazardous situation is not prevented, this will result in death or severe injury.*

*Follow the instructions that accompany this warning to prevent the risk of death and severe personal injury.*

### **⚠ WARNING**

*This warning level indicates a potentially hazardous situation.*

*If the hazardous situation is not prevented, this may result in death or severe injury.*

*Follow the instructions that accompany this warning to prevent the potential risk of death and severe personal injury.*

### **⚠ CAUTION**

*This warning level indicates a potentially hazardous situation.*

*If the hazardous situation is not prevented, this may result in slight or moderate injuries.*

*Follow the instructions that accompany this warning to prevent the injury of persons.*

### **CAUTION**

*This warning level indicates potential damage to property.*

*If this situation is not prevented, it may result in damage to property.*

*Follow the instructions that accompany this warning to prevent damage to property.*

### **NOTICE**

*A notice indicates additional information that will make the handling of the device easier.*

### **1.3 Copyright protection**

These operating instructions have to be treated as confidential. They may only be used by authorised staff. Access by third parties may only be granted upon written agreement of BFI Automation.

All documents are protected in keeping with the German copyright law.

The disclosure and reproduction of documentation, in whole or in part, as well as the exploitation and communication of its content shall not be permitted unless expressly stated otherwise. Offenders are liable for prosecution and the payment of damages.

We reserve all rights to exercise industrial property rights.

### **1.4 Disposal information**

The flame detector is equipped with electrical and electronic components and must be disposed separate from household waste. Follow the local and actual regulations for waste disposal.



### 1.5 Warranty

**Read these operating instructions carefully and in full before operating the flame scanner!**

The manufacturer is not liable for damage or operating malfunctions that result from the operating instructions not being observed.

The operating company has to supplement the operating instructions with operating instructions on the basis of national regulations on accident prevention and environmental protection, including information on supervision and notification requirements with respect to special operating circumstances, e.g. regarding organisation of work, working processes and staff deployed.

The recognised technical rules for safe and professional working also have to be observed in addition to the operating instructions and the regulations on accident prevention applicable to the country and place of use.

The warranty shall become void, for example, in the event of:

- inappropriate use
- use of impermissible equipment
- incorrect connection
- prior works that are not part of the supplied product or service
- non-use of original spares and accessories
- conversion, if this has not been harmonised with BFI Automation
- non-performance of specified maintenance work

#### **NOTICE**

*It is recommended that the operator of the device concludes a service contract with BFI Automation. This guarantees that the device is regularly checked by our service staff and ensures that any required wearing and spare parts are available without long delivery periods.*



## 1.6 Obligation of the operating company

The flame scanner may cause hazards if it is operated inappropriately or in an improper condition.

The operating company is under the obligation to operate the machine in proper state only. The operating company has to secure hazardous areas that exist between BFI devices and the customer's own equipment.

The operating company has to appoint and instruct responsible staff:

- Only deploy trained or instructed staff.
- Clearly set out the responsibilities of the staff with regard to operation, set-up, maintenance and repair.
- Regularly check that staff are safety conscious and aware of hazards and are observing the operating instructions.
- Before starting work, staff who are assigned to work with/on the device have to have read and understood the operating instructions, in particular the chapter on "Safety", as well as the relevant regulations.
- The operating instructions and relevant regulations have to be stored in such a way that they are accessible to operating and maintenance staff.
- Set out who will have responsibility for device operation and ensure that this person has the authority to overrule any unsafe instructions of third parties.

### **NOTICE**

*Generally valid legal and other binding regulations on accident prevention and environmental protection have to be observed and instructed, in addition to the operating instructions.*

### 1.7 Liability disclaimer

All technical information, data and guidance on device operation that are contained within these operating instructions are, to the best of our knowledge, correct at the time of printing, taking into account our present understanding and experience.

We reserve the right to make technical changes with respect to the further development of the flame amplifier outlined in these operating instructions. No claims can be made based on the specifications, illustrations and descriptions of these operating instructions.

We shall not be liable for damage or operating malfunctions that result from operating errors, inappropriate repairs or the non-observance of the operating instructions. We expressly state that only original spare parts and accessories approved by us may be used. This also applies to the components of other manufacturers that have been used.

The installation or use of non-approved spare and accessory parts and any unauthorized retrofits and modifications are not permitted for safety reasons and exclude any liability by BFI Automation for consequential damages.

BFI Automation is liable for possible errors or omissions with the exclusion of additional claims entered into in the framework of the warranty obligations conceded to in the contract. Claims for damages, on whatever legal basis they may be, shall be excluded.

Translations into foreign languages are carried out in good faith. We cannot accept any liability for translation errors; this also applies where the translation has been carried out or has been commissioned by us. The original text alone shall be binding.

Descriptions and illustrations do not necessarily depict the delivered product or a possible spare parts order. Drawings and graphics are not to scale.

## 1.8 Declaration of conformity

### BFI Automation

Dipl.-Ing. Kurt-Henry Mindermann GmbH  
 Eggerscheidter Strasse 57  
 D-40883 Ratingen  
 Germany

## Declaration of Conformity in accordance with EC-Directives

This is to confirm that the below described system in its design and type of construction complies with the provisions of the Directive of the Council of the European Communities on the approximation of the laws of the member states relating to

**Low-Voltage Directive 2006/95/EC**  
**EX Directive 94/9/EU (ATEX 95)**  
**EMC Directive 2004/108/EC**

This declaration of conformity of the European Communities is the result of an examination of the TD Department of BFI Automation in accordance with the European Standards. If the system will be changed without our approval this declaration will become invalid.

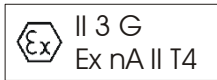
Description of the system:	Flame Monitoring System 3000/4000	
Part type:	2.0GT (in combination with a flame amplifier type 3001, 3001D, 3001S or 4001)	
Directives:	2006/95/EC, formerly 73/23/EWG 94/9/EC(ATEX95), formerly ATEX 100a 2004/108/EC, formerly 89/336/EWG	
Applicable European Standards:	EN 55022, EN 50082-2 EN 298:2012 EN 50156-1, EN 60664-1 EN 60079-15 (Flame Scanner)	
Sign of the Equipment regarding Ex	Standard Housing	
Date / Manufacturer signature:	2014-01-30 <i>J.-M. Mindermann</i>	
Function of the signatory:	General Manager	

### 1.9 Address of the manufacturer

BFI Automation  
Dipl.-Ing. Kurt-Henry Mindermann GmbH  
Eggerscheidter Strasse 57  
D-40883 Ratingen  
Germany

Tel. +49 (2102) 9682-0  
Fax. +49 (2102) 9682-42

Email: [info@bfi-automation.de](mailto:info@bfi-automation.de)  
Internet: [www.bfi-automation.de](http://www.bfi-automation.de)

## 2 Safety

### 2.1 Intended use

The flame scanner shall be used exclusively to detect flames in combination with a suitable flame amplifier. The flame scanner and flame amplifier together constitute a complete flame amplifying system for burners with a random capacity and random fuels in single and multiple burner systems.

The flame amplifier renders available to the burner control the safety-oriented binary signals for "Flame ON/OFF".

On account of the continuous fully electronic self-test of its function, the flame scanner is approved for continuous operation.

#### **⚠ WARNING**

*Danger when improperly used !*

*The device may cause hazards if it is not used as intended and/or for any other purposes.*

*The device has to be used only for the purposes for which it is intended.*

*The procedures described in the operating instructions have to be observed.*

The manufacturer/supplier shall not be liable for damage resulting from use for non-intended purposes. The user/operating company alone shall bear the risk.

## 2.2 Requirements on persons

### **NOTICE**

*Work on/with the device may only be performed by persons authorized to do so based on their training and qualification. Furthermore, such persons have to have been commissioned by the operating company.*

Do not allow any persons who are being apprenticed, educated, instructed or on a general training programme to work on the device without the constant supervision of an experienced person.

Persons who are under the influence of drugs, alcohol or medication that affects reactivity shall not be permitted to carry out work on the device.

Connection, set-up, maintenance and repair work may only be carried out by qualified specialist staff.

This device may cause hazards if it is operated inappropriately by untrained staff or if it is not used for its intended purpose.

Generally valid legal and other binding regulations on accident prevention and environmental protection in addition to basic health and safety requirements have to be observed. The operating company has to instruct its staff accordingly.

## 2.3 Safety instructions

The following instructions on accident prevention have to be observed when operating the flame scanner.

### **NOTICE**

*Only operate the device if it is in a proper state !*

- Do not remove or disable safety devices.
- Check for externally noticeable damage and defects prior to using the device ! Immediately notify the appropriate authority/person of any changes that occur (including changes in operating performance). If necessary, stop and secure the device immediately.
- Allow only authorised specialist staff to carry out set-up and/or maintenance work.
- Replace worn or defective parts.
- Use suitable maintenance tools only.
- After repair work, refit all safety devices and carry out electrical and mechanical checks.
- Check the operating instructions for details of displays as well as switch-on and switch-off procedures.
- Prior to switching on the device, make sure that no-one can be endangered by the device !
- The operating instructions always have to be kept close to the device and be readily at hand.
- Any non-compliance with the safety instructions outlined in these operating instructions may lead to damage to property, personal injury or even death.

## 2.4 Safety devices

### 2.4.1 Fundamental aspects

Check the safety equipment and locking devices on the device for safe operational condition.

Only operate the device if all safety devices are present and enabled. The operating company or operator of the flame scanner is responsible for the proper operation of the device.

#### **NOTICE**

*The device has been fitted with warning and danger signs for the protection of operating staff. These signs have to be observed. Damaged or illegible signs have to be replaced immediately.*

### 2.4.2 Safety devices on the flame scanner

The flame scanner has been fitted with the following safety devices:

- Housing (protection against accidental contact)
- Flame-proof housing (optional)
- Earth connection of device (optional)
- Explosion protection barriers (optional)



## **2.5 Safety instructions in case of maintenance and troubleshooting**

### **2.5.1 Fundamental aspects**

- Deadlines set or indicated in the operating instructions for repetitive checks / inspections shall have to be observed !
- Appropriate workshop equipment is essential for performing maintenance work.
- In conformity with the electrical regulations, work on the electrical equipment of the system may only be carried out by an electrical specialist or by trained staff under the direction and supervision of an electrical specialist.
- The adjustment, maintenance and inspection activities and deadlines stipulated by BFI Automation, including information on the replacement of parts / assemblies, have to be observed! These tasks may only be carried out by authorised specialist staff.
- Operating staff have to be informed before maintenance or other special work is carried out. A supervisor has to be appointed.
- Screw connections which have been loosened during maintenance and servicing work, have to be tightened.
- If maintenance and repairs require safety devices to be dismantled, these devices have to be remounted and checked as soon as the maintenance and repair work has been completed.
- Operating and auxiliary materials as well as exchanged parts have to be disposed of in a safe and eco-friendly way.
- Spare parts supplied by BFI Automation or approved of by BFI Automation only may be used.

## 2.5.2 Electrical / electronic devices

### **⚠ DANGER**

*Danger to life caused by electrical current!*

*Contact with live wires or components presents a danger to life !*

*Prior to any work on the electrical equipment, disconnect the flame amplifying system from the power supply network !*

### **NOTICE**

*In keeping with the electrical regulations, work on electrical / electronic parts / components may only be carried out by electrical specialists.*

#### **Important rules of conduct**

- Check the device in regular intervals. Any defects or faults ascertained have to be corrected immediately. Switch off the device until the defects have been corrected.
- Equipment parts undergoing inspection, maintenance or repair work have to be made de-energised, if required. First check that the disconnected parts are no longer live, then short to earth. Also isolate neighbouring live parts
- If work is required on live parts, a second person has to be assigned who can disconnect the power supply in case of an emergency. Only use insulated tools !
- Fuses must not be repaired or bridged. Only use original fuses with the specified current !

### **2.5.3 Testing in keeping with the German Workplace Safety Ordinance (BetrSichV)**

In case of the coupling or installation of devices from various manufacturers or suppliers, the operating company has to carry out a precise test, prior to start-up, in keeping with the German Workplace Safety Ordinance (BetrSichV) in force and the applicable electrical regulations.

In case of queries, please get in touch with BFI Automation.

### **2.5.4 Safety test**

**⚠ WARNING**

*In order to ensure correct operation, the flame scanners as well as flame amplifiers of all applications have to be tested several times by starting and stopping the burner several times. In all cases the flame relay has to be switched off reliably in case of an absent flame. Carry out this test whilst several neighbouring burners are started and stopped and different boiler outputs are used. This is an indispensable pre-requisite for a safe and correct operation of the device !*



### 3 Technical data

#### 3.1 General characteristic features

- Self-control to verify flawless function of the device in keeping with European standard EN298 :2012
- Two spectral bands separately adjustable
- Selective amplifying of gas and oil firing systems
- Si and PbS sensor
- Fully electronic construction
- Spectral analyzing process
- Tested by the German Technical Inspection Association TÜV
- Approved of by DIN DVGW
- Suitable for safety related applications up to SIL 3 (according to IEC 61508)

#### 3.2 Electrical system, optical system, mechanical system

Item	Value
Spectral sensitivity	300 to 2700 nm
Angle of view	1°, 2° or 2.7° (UV – IR)
Self-monitoring	fully electronic, 1 x per second
Operating voltage	24 VDC, isolated internally
Current consumption	max. 200 mA
Operating temperature	-20 °C to +70 °C (-4 °F to 160 °F)
Electrical connection	dust-proof plug-type connector
Type of protection	IP 65
Cable length	Max. 500 m (KW5)
Sight tube connection	1" internal thread ISO 228
Purge air connection	½" internal thread ISO 228
Purge air volume	10 m³/h at standard conditions

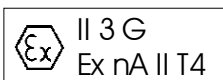
Purge air pressure	0.02 bar over the internal pressure of the combustion chamber
Ex-marking	
Approvals	
CE	CE0085BS0478
DVGW	NG2530AS0248
CSA	1150499
SIL 3	968/EL440.01/13

### 3.3 Weight

Weight approx. 1.5 kg

### 3.4 Dimensions

Length 235 mm  
 Width 108 mm  
 Height (with plug) 190 mm

## 3.5 Adjustment controls

### 3.5.1 Sensitivity potentiometer

The potentiometer is used to set the amplification of the flame signal in the flame scanner. The adjustment cannot be carried out during the operation as the potentiometer is located behind the lens plate. Remove the yellow protective sticker on the lens plate for adjustment. The scanner type 2.0GT has been fitted with two potentiometers. The potentiometer located near to the lens plate be used to set the PbS scanner for the spectral range 1050 - 2700 nm. The potentiometer located away from the lens plate is used to set the Si scanner for the spectral range 300 to 1050 nm.

#### **NOTICE**

*The following applies for both potentiometers: Increase of sensitivity by turning clockwise !*

The potentiometers are set from 0 to 100 per cent by turning 24 full turns. It is not possible to overturn the potentiometer.

### 3.5.2 Optical aperture

The flame scanner, type 2.0GT, has been fitted with an optical aperture. The aperture permits a control of the radiation energy, which is picked up as flame signal by the semi-conductor sensor. It is used to fade out excessive radiation emitted by heavy oil flames, for example, by optical means. An overexcitation of the scanner electronics or a thermal overload of the scanners can be prevented.

#### Adjustment of the aperture

The unit has to be opened for the adjustment of the aperture (four cross-recessed screws on the lens plate below the sponge rubber disk). The aperture is located between the lens and the detector holding block. In order to be able to change the aperture setting, the rotational axis screw (1) has to be loosened first of all. Then loosen the set screw (2) until the aperture can be moved. Set the requested aperture (3-5) and lock the position with the set screw (2). Subsequently tighten the rotational axis screw (1) and close the device.

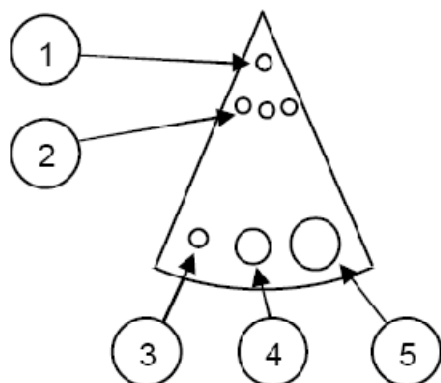

- 1 rotational axis
- 2 set screw
- 3 small aperture
- 4 medium aperture
- 5 big aperture



### 3.6 Device design - block diagram of the flame scanner

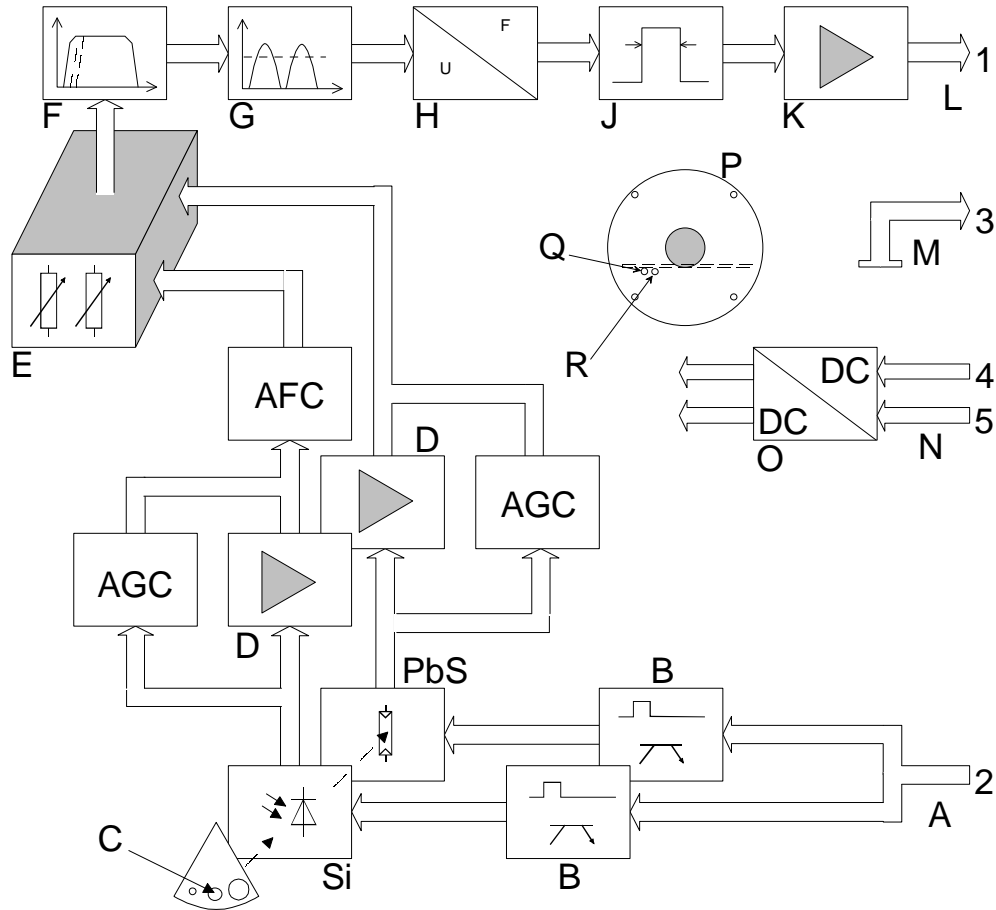

- |       |                                    |     |                             |
|-------|------------------------------------|-----|-----------------------------|
| 1 – 5 | pin number in the Harting plug     | J   | pulse shaper                |
| A     | system shutter puls                | K   | output stage                |
| B     | electronic shutter                 | L   | signal output               |
| C     | optical aperture                   | M   | Signal GND                  |
| D     | pre-amplifier                      | N   | power supply                |
| E     | mixing stage                       | O   | DC/DC Converter             |
| F     | band pass                          | P   | lens plate                  |
| G     | full-wave rectifier                | Q   | potentiometer for UV-NIR    |
| H     | U/F converter                      | R   | potentiometer for NIR-IR    |
| Si    | semi-conductor sensor Si (UV-NIR)  | AGC | automatic gain control      |
| PbS   | semi-conductor sensor PbS (NIR-IR) | AFC | automatic frequency control |



## 4 Transport, installation and connection

### NOTICE

*All installation and connection work may be carried out by qualified and approved specialist staff only !*

*Observe the legal stipulations and adjustment instructions of the plant operator !*

### 4.1 Scope of delivery

- Flame scanner 2.0GT
- Operating instructions BA 2.0GT EN
- Connection cable (optional)
- Harting connector set (set) and/or complete
- Ball flange (optional)
- 3-way-ball-valve (optional)
- Heating insulator (optional)
- Optical alignment device (optional)

Refer to the order papers for the exact scope of delivery and compare with the delivery note.

Checking for completeness

Check the entire delivery for completeness against the accompanying delivery note. Please refer to our terms of sale and delivery otherwise.

Report any damage

After arrival of the device and accessories, notify the shipping agent, the insurance company and BFI Automation immediately in case of any damage caused by transport or inadequate packaging.

Take steps to minimise and prevent further damage.

Report the insurance case to the insurance company without delay and transmit the full claim documents at once in order to expedite the claims settlement (at the latest in sufficient time before the expiry of any periods of preclusion and/or limitation relating to the compensation claims against third parties).

## 4.2 Packaging

The flame scanner is shipped in different packaging materials.

The most frequently used packaging materials are cardboard and plastics (foils, foamed material).

### NOTICE

*Packaging has to be disposed of in an environmentally friendly way and in accordance with the relevant provisions on disposal.*

## 4.3 Forwarding instructions

### NOTICE

*Do not subject the appliance to heavy impacts during transport. Do not subject the appliance to any humidity !*

## 4.4 Weight - flame scanner

1.5 kg

## 4.5 Space requirement

See following illustration.

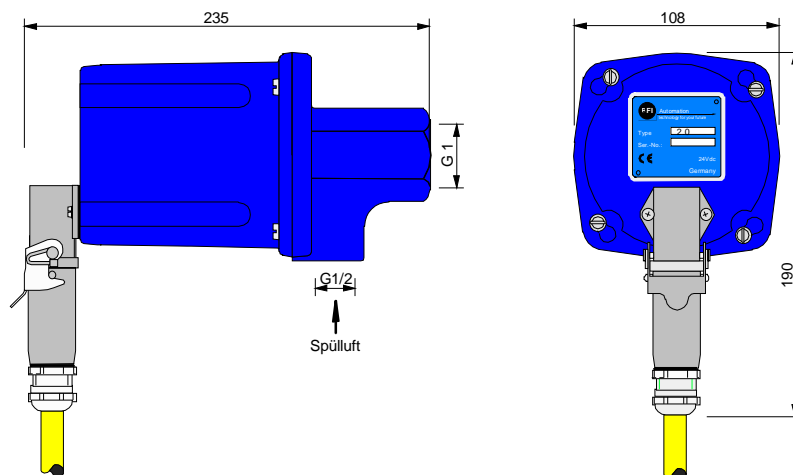

## 4.6 Installation

### NOTICE

*All installation and connection work may be carried out by qualified and approved specialist staff only ! The legal regulations as well as adjustment instructions of the plant operator have to be observed !*

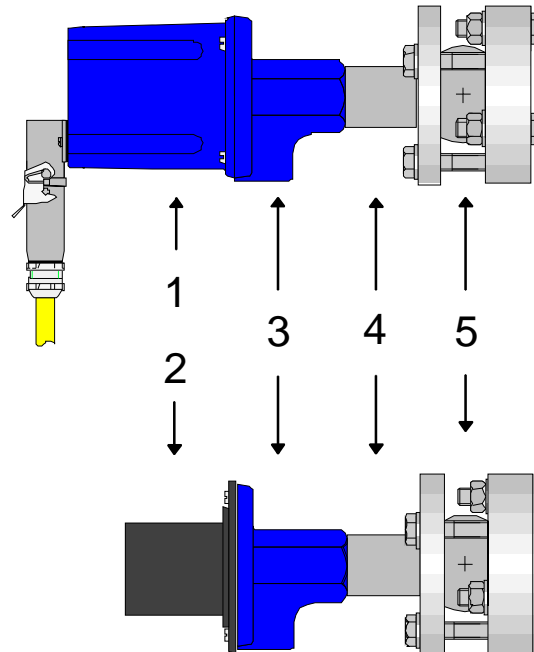

- |                            |                     |
|----------------------------|---------------------|
| 1 Flame scanner            | 4 Heating insulator |
| 2 Optical alignment device | 5 Ball-flange       |
| 3 Purge air flange         |                     |

The flame scanner has been provided with oblong holes for easy installation on the purge air flange. Counter all four M5 screws with nuts and fit U-disks and lock washers.

The sighting tube connection has been provided with a G1" internal thread.

In order to ensure perfect flame amplifying, the correct and low-vibration position of the sighting tube relative to the flame is essential. The flame scanner has to be aligned in such a way that a perfect visual image is set. For this purpose use the optical adjusting device (available as an accessory) as shown in the following illustration.

The best setting results when a large visual field is achieved.

**CAUTION**

*Danger of injuring the eyes by infrared and ultraviolet radiation and penetrating gases when checking the flame visually !*

*Wear filtering protective glasses !*

Vision images of the optical adjustment device

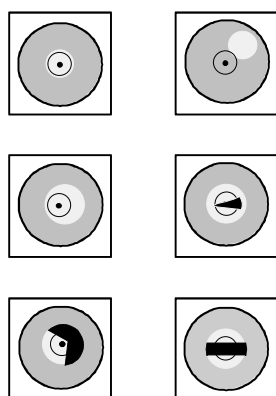

correct

wrong

**NOTICE**

*The images appear mirror inverted in horizontal and vertical direction !*

The length and the diameter of the sighting tube have a direct influence on the usable flame radiation as the visual angle of the lens system is defined. Without restriction of the visual range, the maximum length L of a sighting tube for conventional tube diameters D is as follows:

D:	1"	1.5"	2"
L:	0.5 m	0.8 m	1.1 m

For this reason, the sighting tube should always be as short as possible. A diameter of 2" is recommended.

**NOTICE**

*At a diameter of 1", the sighting tube should not be any longer than 50 cm. When doubling the length, double the diameter to 2" !*

By using a ball-flange (optional, part No. 6590-9020-01), the adjustment can be carried out easily ensuring that the ideal sighting point is set mechanically. The flame scanner is supplied complete with a rapid-installation flange. This flange ensures the unproblematic disassembly of the flame scanner. It has a purge air connection, the construction of which prevents the soiling of the lens system without the dust-laden purge air damaging the lens. If temperatures of over 50 degrees Celsius occur at the flame scanner despite the inflow of cooling air caused by the heat dissipation of the sighting tube, heating insulator (optional, part No. B 512.1) has to be used. In case of pressurised combustion, an additional 3-way-ball-valve (optional, part No. B 520) has to be fitted for protection. The exit of hot gas after removal of the scanner is prevented, ensuring further cooling and purging of the arrangement.

The entire mechanical peripheral system can be supplied by BFI Automation.

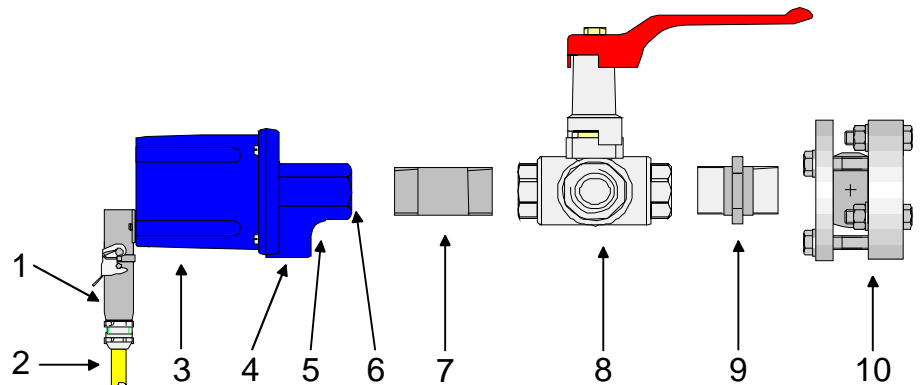

- |                        |                            |
|------------------------|----------------------------|
| 1 Harting plug         | 6 Sighting tube connection |
| 2 Special cable KW5    | 7 Heating insulator        |
| 3 Flame scanner        | 8 3-way-ball-valve         |
| 4 Purge air connection | 9 Double nipple            |
| 5 Purge air flange     | 10 Ball-flange             |

### 4.6.1 Company adjustment of the flame scanner

**⚠ DANGER**

*Danger to life caused by combustion or explosion !*

*In case of incorrect installation or adjustment, uncontrolled combustion or explosions may be caused !*

*Observe the adjustment instructions of the plant operator !*

*Adjustment work may be carried out only by qualified and approved specialist staff !*

The sensitivity of the flame scanner has been factory set to approx. 50% for each spectral range.

The optical aperture has been preset to "small aperture" by the manufacturer, which provides sufficient adjustment reserve for more radiation input. This aperture setting has been approved for flame monitoring on gas turbines.



**4.6.2 Adapting the flame scanner to the fuel**

**⚠ DANGER**

*Danger to life caused by combustion or explosion !*

*In case of incorrect installation or adjustment, uncontrolled combustion or explosions may be caused !*

*Observe the adjustment instructions of the plant operator !*

*Adjustment work may be carried out only by qualified and approved specialist staff !*

**NOTICE**

*All alignments and settings have to be carried out, when new spare parts have been fitted, the flame scanner has been moved or the flame image has been changed (by additional fuel, new burner, change in the burner / air register, for example) as well as during all first installations.*

For selective burner amplifying, the device has to be installed in such a way that the primary combustion zone in all load ranges is inside the visual angle of the flame scanner. The sight axle has to cut through the first third of the flame (A) of the own burner if possible. The extension of the sight axle must not cut through the first third of the flame of other burners.

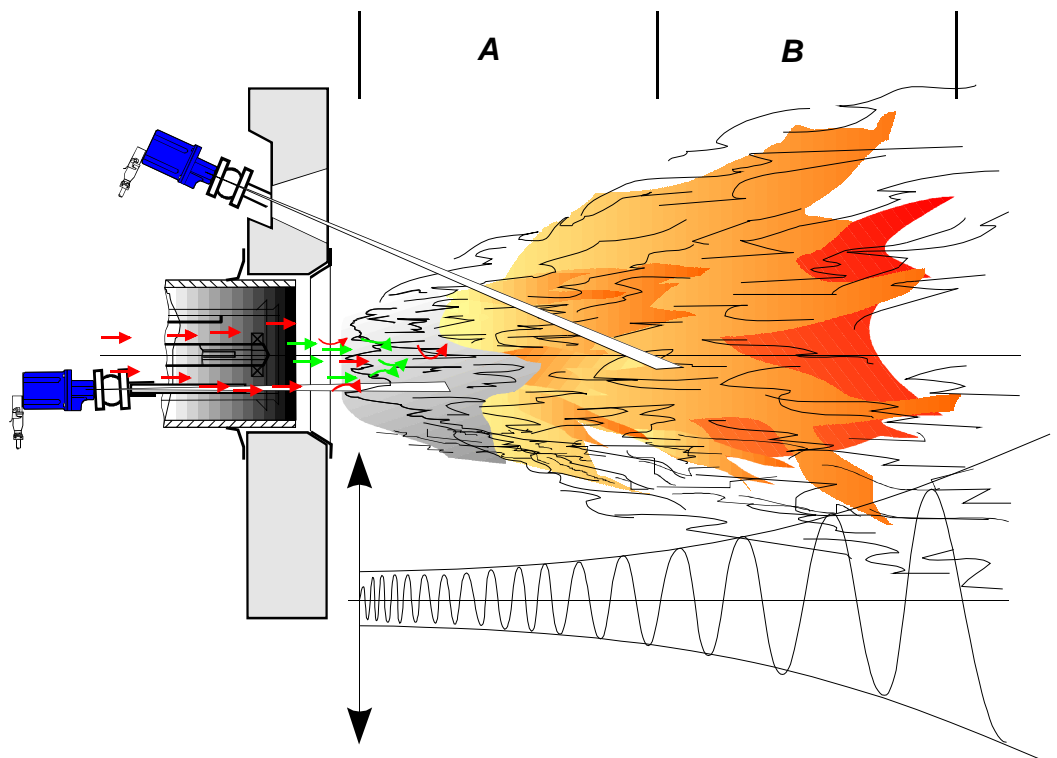

## 4.7 Connection

### 4.7.1 Electrical connection

**⚠ DANGER**

*Danger to life caused by electrical current !*

*The safety instructions and local safety regulations have to be observed during connection !*

For connection data, please refer to the chapter titled "Technical data" as well as to the following terminal diagram.

Ensure that the available supply voltage complies with the voltage indicated on the type plate.

Prior to connection, check the device and the connecting cables for visible damage.

#### Terminal diagram

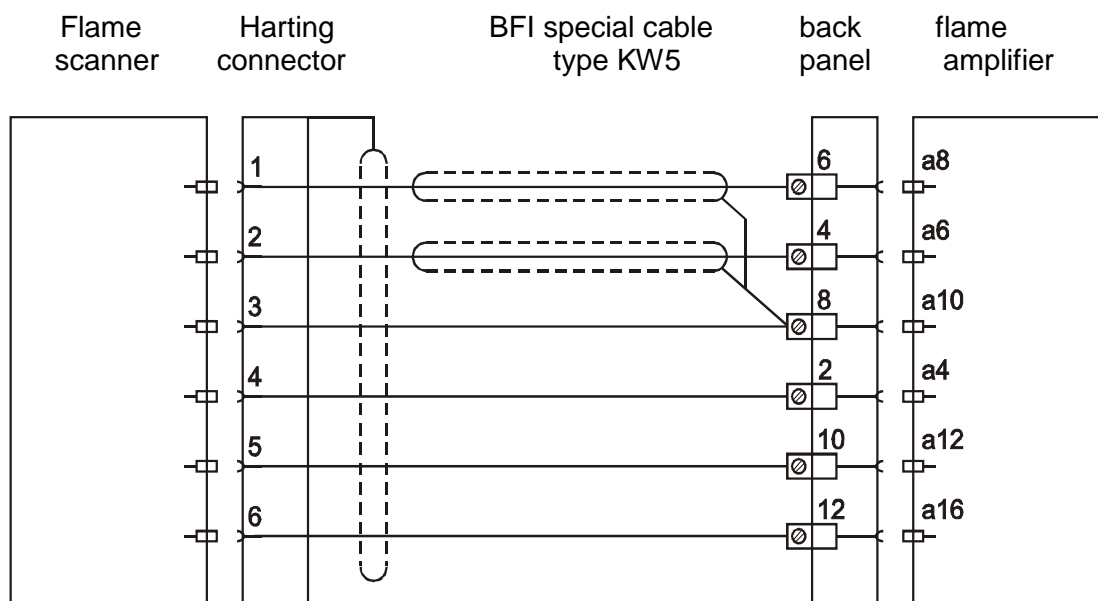

Harting connector	Function	Colour of conductor	Backpanel contact	3001 contact
1	Flame signal	wh	6	a8
2	Shutter puls	br	4	a6
3	Signal GND	pk	8	a10
4	Power supply +24 VDC	gn	2	a4
5	Power supply GND	ye	10	a12
6	Reserve	gr	12	a16

**NOTICE**

*Prior to the connection of the flame scanner, observe the separate operating instructions of the flame amplifier (System 3000 / 4000) !*

**4.7.2 Laying the special cable KW5**

**NOTICE**

*No contact chamber may remain bare !*

*All contact chambers in the contact insert have to be fitted with crimp contacts !*

*For this purpose use a suitable crimp tool (BFI part No. 8980-4801-00) !*

On the flame scanner side the external shielding is connected to the housing mass by means of a clamp connection located between the plastic insert the threaded part in the cable gland (not available in KW3 cable). The internal shielding is cut on the flame scanner side and is connected to the flame amplifier side along with the signal GND (see terminal diagram).

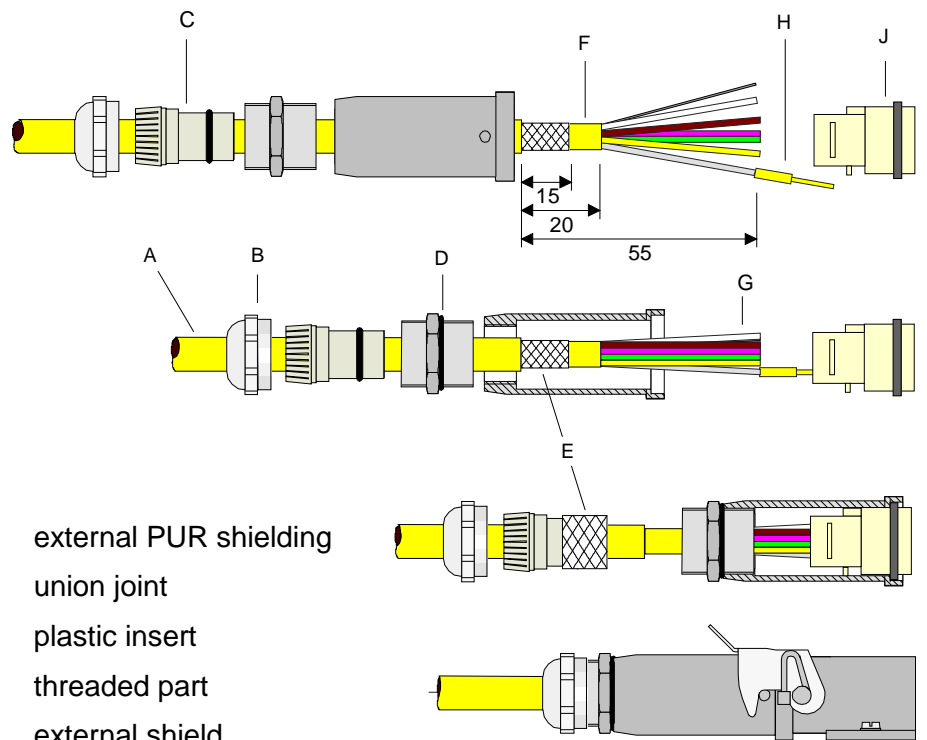

- A: external PUR shielding
- B: union joint
- C: plastic insert
- D: threaded part
- E: external shield
- F: internal PUR shielding
- G: individual wires
- H: crimp contact
- J: female contact

### 4.7.1 Handling of the KW5-Shieldings

#### **Outer shielding:**

The outer shielding is only connected to the device via the cable gland. On the loose cable end the shielding should be cut off short.

#### **Inner shielding:**

The inner shielding has to be connected to ground of the flame amplifier side.

## 4.8 Storage

Do not unpack any packed flame scanners and accessories.

The following conditions apply to storage:

- Store in a dry place. Maximum relative humidity 60 %. In addition, It has to be assured that the floor in the storage area will remain dry throughout the storage period.
- Protect from direct sunlight. Storage temperature: 15 °C to 25 °C (59 °F to 77 °F).
- Store in a dustfree location.
- Avoid mechanical vibrations and damage.

## 5 Description

### 5.1 Functional description

The flame scanner 2.0GT operates on the basis of the spectral analysis method of the UV-VIS and IR flame radiation analysis. Both spectral ranges are converted separately by a dual detector and are analysed selectively with an automatic pre-amplifier and integrated frequency controller.

The high-frequency flame modulation of the primary combustion zone is utilised in an ideal manner in this way. Cancellation of the UV-VIS flicker frequencies cannot occur again as the high-energy IR radiation is processed separately. The usually undesired continuous-light part of the flame is used for the fuel-specific control of the flame scanner. A dual detector consists of a lead sulfide carrier, to which a silicon photo element has been deposited by evaporation. The Si element thus acts as an UV filter in front of the PbS elements, which is located on the same axis. Thus, the short-wave radiation part is blocked out which otherwise could lead to problems in the use of PbS detectors. The compensation controlled by the ambient temperature stabilizes the operation point of the flame scanner and maintain the spectral linearity. The signals of both photo-elements results in an aggregate signal of a every large spectral bandwidth in the mixed stage. Among other things, the spectral shift of the flame renders information on the oxidation of the fuel and thus on the quality of combustion.

The signal parts of the UV-VIS and IR radiation intensities can be set separately in order to exhaust the potentialities of flame analysis to the full. The downstream bandpass ensures that the typical flame radiation modulation of the primary combustion zone only is used for the output signal. The other functional groups are used for conversion into standardized digital information in the biggest possible interference safety.

The flame scanner has been fitted with an optical aperture. The aperture permits a control of the radiation energy, which is picked up as flame signal by the semi-conductor sensor. It is used to fade out excessive radiation of heavy oil flames, for example, by optical means. This prevents an overexcitation of the scanner electronics or a thermal overload of the semi-conductor sensor.

## Description

---



## 6 Operation of the flame scanner

### **NOTICE**

*For the operation of the flame scanner, please observe the separate operating instructions of the flame amplifier.*

### **NOTICE**

*The response of the flame scanner depends on the burner configuration as well as on the air flow and the spectral characteristic (wave length).*

### 6.1 Test of the flame scanner

#### **NOTICE**

*Please also refer to the separate operating instructions of the flame amplifier !*

In order to ensure correct operation, the flame scanners as well as flame amplifiers of all applications have to be tested several times by starting and stopping the burner several times. Carry out this test whilst several neighbouring burners are started and stopped and different boiler outputs are used. This is an indispensable pre-requisite for a safe and correct operation of the device !





### 7 Maintenance and servicing

The flame scanner requires no maintenance.

For cleaning, use a moist cloth to wipe the housing from the outside only.

**NOTICE**

*Do not scratch the lens !*



## 8 Failures

Problem:	Display:	Cause:	Remedy:
No flame - <i>ON</i> signal after the burner has been started	No analogue signal LED RF <i>OFF</i> LED RM <i>OFF</i> LED time I / time II <i>OFF</i>	Flame amplifier is not operational	Check power supply Check fuse F101 (F 0.8 amps) Replace flame amplifier Check electrical connection
	Analogue signal < 25 % LED RF + RM <i>OFF</i>	Flame signal too low	Check flame scanner Check / set sensitivity
	Analogue signal 25 - 75 % LED RF <i>OFF</i> LED RM <i>ON</i>	Flame signal below the switch-ON threshold	Increase sensitivity Reduce switch-on threshold
	Analogue signal 25 - 100 % LED RF <i>ON</i> LED RM <i>OFF</i>	Self-test error	Check / set switch-off times Check cable shield Replace flame scanner Replace flame amplifier Check installation including cable routes for EMC sources High voltage / radio
	Analogue signal 25 - 100 % LED RF + RM <i>ON</i>	Relay contact or wiring problem	Check fuse F102 (T 1 amp) Check electrical connection
Burner trips	Analogue signal falling below 25 %, switch <i>OFF</i> RF + RM.	No flame, weak flame signal	Check flame Check flame scanner Check flame scanner alignment, sight tube and lens Increase sensitivity setting Replace flame scanner Replace flame amplifier Check electrical connection
	Analogue signal > 25 % RF <i>ON</i> RM goes <i>OFF</i>	Self-test error	Check cable shield Check flame scanner cable for EMC interfering source



## 9 Order data

Flame scanner 2.0GT is available from BFI Automation GmbH under the following order data:

Flame scanner in standard housing zone 2	
Typ	Material-No.
2.0GT	S 507H



## 10 Accessories

Accessories	
Typ	Material-No.
Swivel mount 1" with 2" flange plate	6590-9020-01
3-way ball valve 1"	B 520
Heating insulator 1"	B 512.1
Double nipple 2 x 1" outer thread	B 500
Special cable KW5	6060-0560-65
Optical alignment device BFI 235	P 106

More information about BFI Automation and our products  
you find under:

## Product catalog

Download under

[http://www.bfi-automation.de/download/bfi\\_pk\\_en\\_digi.pdf](http://www.bfi-automation.de/download/bfi_pk_en_digi.pdf)

or

with QR-Code



## Image brochure

Download under

[http://www.bfi-automation.de/download/image\\_en.pdf](http://www.bfi-automation.de/download/image_en.pdf)

or

with QR-Code

